

**FUJIKURA COMPOSITES**

Precision Electro-Pneumatic Transducers

RT SERIES

- ▶ An electric signal permits stepless control of pneumatic pressure.

The air in the secondary pressure chamber is used to control the nozzle and flapper systems to ensure very high accuracy characteristics.

**FUJIKURA RUBBER LTD.**

Features

High-precision control

High-precision pneumatic pressure control with the linearity of 1.0-1.5% F.S. and hysteresis of 1.0% F.S. is possible.

Outstanding pressure characteristics

The output pressure fluctuation is within 0.5% F.S. with respect to the primary pressure fluctuation.

Flow characteristics

As is the case with an ordinary reducing valve, this converter can secure a flow rate sufficient to directly control pneumatic equipment. The repeatability of intermittent load is within 0.5% F.S.

Free installation position

There is no limitations on the installation position. However, zero adjustment and span adjustment are necessary.

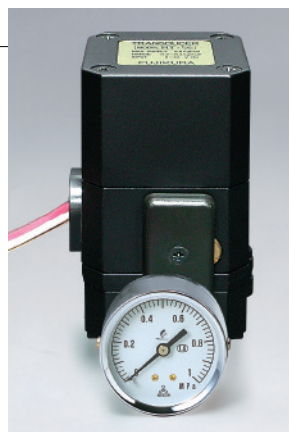

Wide adjusting range

The span adjusting screw can change the span points within the range of 0.65 - 0.84 MPa for RT ㄷ/P-8-2 and 0.24 - 0.84 MPa for RT ㄹ/P-8-2.

Compact

This converter is a compact type with the major dimensions of 54 x 54 x 105. It can save the installation space.

Specifications

Item		Model	RT·E/P-8-2	RT·I/P-8-2
Working Fluid			Clean Compressed Air	
Set Pressure Range	MPa		0.02 ~ 0.84	
Supply Pressure Range	MPa		Max. 0.99; set pressure: +0.035 or more	
Input signal	Control method		Voltage 2-line type	Current 2-line type
	Voltage	VDC	0 ~ 10	—
	Input impedance	Ω	805	—
	Current	mADC	—	4 ~ 20
	Input impedance	Ω	—	260
Linearity	%F.S.		1.5	
Hysteresis	%F.S.		1.0	
Repeatability	%F.S.		± 0.1	
Step response	Sec		1.0 or less	
Span adjustment lower limit	MPa		0.65	0.24
Relief Flow Rate	MPa		Set pressure +0.001 or less	
Air Consumption	NL/min		3.7 or less	
Operating Temperature	℃		5 ~ 60	
Pipe Port	Rc		1 / 4	
Gauge Port	Rc		1 / 4	
Bracket			Standard Equipment	
Weight	kg		0.94	

Pressure gauge (option)

eModel	G025	G060	G100
Pressure Range	MPa 0 ~ 0.25	0 ~ 0.6	0 ~ 1
Min. Graduation	MPa 0.005	0.01	0.02
Port size	R1/4		
Accuracy	± 1.6% F.S.		
Weight	g	125	

JIS symbol

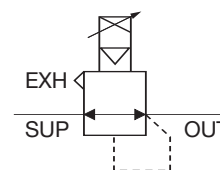

MODEL DESIGNATION

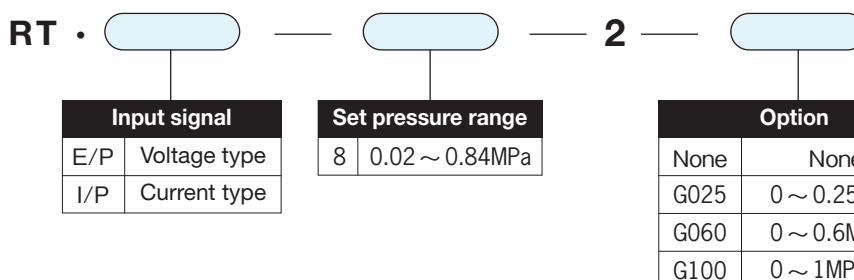

Examples of application

- Tension control by dancer roll
- Tension control by air brake
- Dispenser-control of various types of fluid
- Control by the pneumatic pressure of control valve
- Control of application quantity based on a program
- Control of welding pressure of spot welding gun
- Control of pressing force of polishing machine
- Control of pressure of balancer and lifter
- Control of handling force of robot

Characteristic

Pressure Characteristic

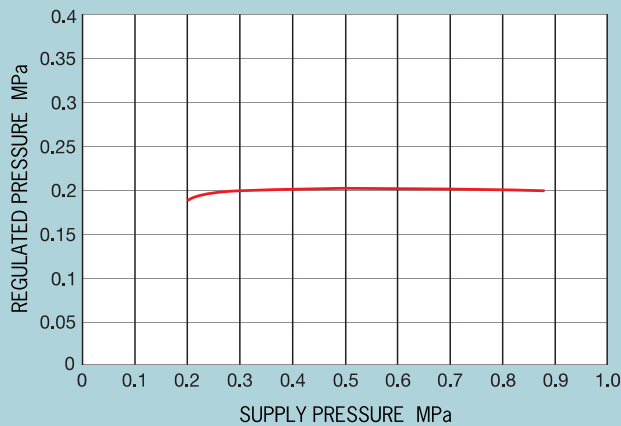

Flow Characteristic

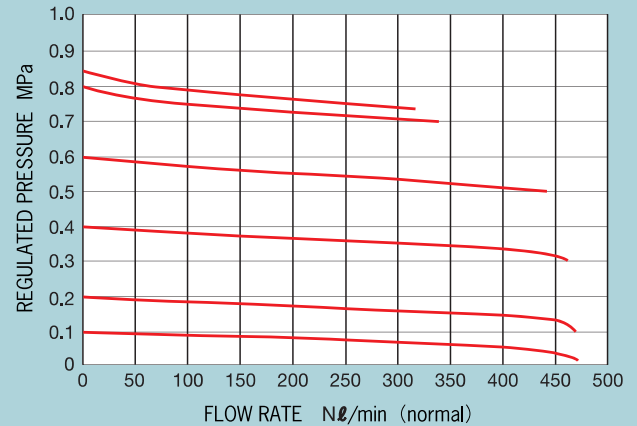

Explanatory construction and Principle of operation

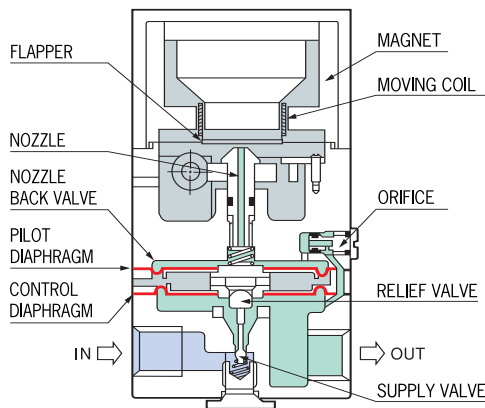

When the input signal increases, the coil output increases and presses down the flapper. As a result, the gap between the flapper and nozzle decreases, and the backpressure of the nozzle increases. Then the pilot pressure increases to open the main valve, and the secondary-side pressure increases.

When the coil output balances with the pressure receiving force caused by the nozzle backpressure plus the reaction force of the flapper, the secondary-side pressure stops increasing and stabilizes.

Based on the above operation, a pneumatic pressure that is proportional to the magnitude of the electric signal can be generated on the secondary side.

Concomitant use of ultraprecision air relay RR Series

Input of the secondary pressure of the electropneumatic converter RT Series as the pilot pressure of RR ensures tension control and excellent characteristics applicable to an air balancer, etc.

Main specifications of RR Series

Pressure setting range	0.014 ~ 0.84MPa
Repeatability	Within $\pm 0.1\%$ F.S.
Minimum relief pressure	0.00003MPa (Theoretically calculated value)

- For details, refer to CAT. No. KS-128E.



CAUTION

1. Use clean compressed air (impurities to be less than 5 μ m) within the operating pressure range.
 2. Entry of foreign matter into the piping will cause malfunction.
 3. Do not use any lubricator.
 4. When screwing joints into the main unit, exercise care so that the seal tape will not get inside.
 5. When the IN-side connecting port and OUT-side connecting port are connected reversely, the electropneumatic converter and other equipment may be broken.
 6. Avoid installation in a place subject to vibration. Install the converter sufficiently away from induction loads (solenoid valve, motor, relay, etc.) and high-tension cables.
 7. The zero point and span are adjusted in the erected state. If the zero point changes when the converter is installed in any position other than the erected state, adjust the zero point and span.
 8. When the preset pressure is held for a long time, it will change by approx. 2.5% F.S. as time passes.
- This converter is developed exclusively for pneumatic equipment. Do not use it for medical equipment.

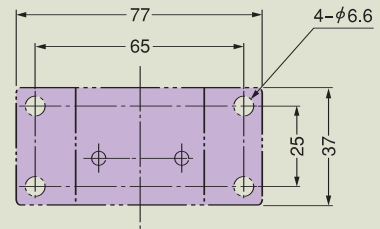
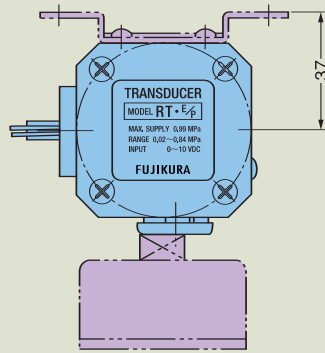

Bracket mounting dimensions

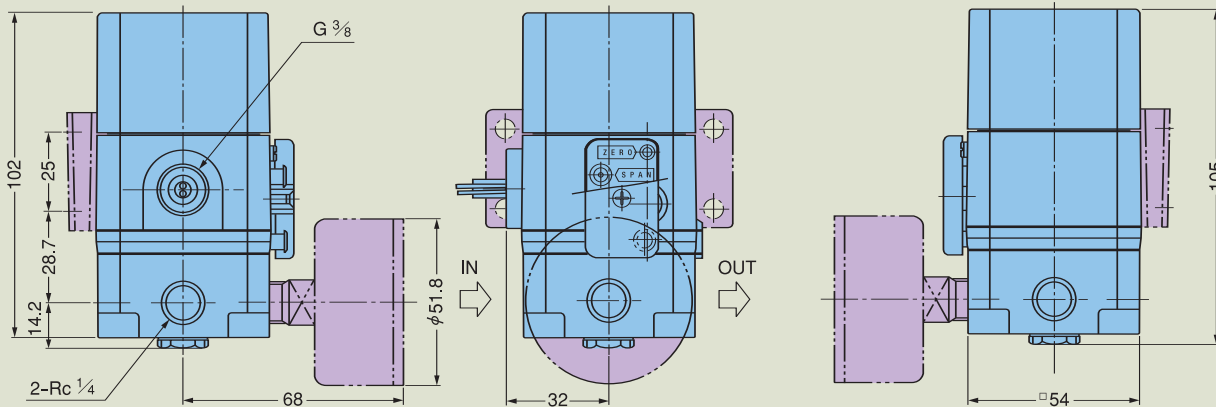

FUJIKURA RUBBER's pneumatic equipment

■ General Guide	CAT. No. KS-572E	■ Miniature Regulators	seriesRA } CAT. No. KS-794E
■ Super Precision Air Regulators	seriesRS } CAT. No. KS-128E	■ Thin-Type Precision Air Regulators	seriesRB } CAT. No. KS-794E
■ Super Precision Air Relays	seriesRR } CAT. No. KS-128E	■ Miniature Precision Air Regulators	seriesRP1 CAT. No. KS-183E
■ Compac Super Precision Air Regulators	RS2 CAT. No. KS-0394E	■ Relief Regulators	seriesRG1 CAT. No. KS-198E
■ Precision Air Regulators	seriesRP CAT. No. KS-129E	■ Fujikura BF Cylinder	seriesVR1 CAT. No. KS-187
■ Compact Precision Air Regulators	seriesRP2 CAT. No. KS-0393E		seriesFC CAT. No. KS-570-01E
■ Precision Electro-Pneumatic Transducers	seriesRT CAT. No. KS-130E		seriesSC CAT. No. KS-9137E
■ Super Precision Electro-Pneumatic Transducers	seriesRT2 CAT. No. KS-0395E		seriesPC CAT. No. KS-570-02
■ Precision Vacuum Pressure Regulators	seriesRV CAT. No. KS-131E		seriesTC CAT. No. KS-570-03
■ Miniature Precision Vacuum Pressure Regulators	seriesRV2 CAT. No. KS-0305E		seriesTD CAT. No. KS-0373



FUJIKURA RUBBER LTD.

Control Equipment Division :

840, Mihashi 1-chome, Omiya-ku, Saitama-city,
SAITAMA PREF. 330-0856, JAPAN
Phone: 81-48-663-1820
Facsimile: 81-48-663-8630
URL <http://www.fujikur rubber.com/ced/>
E-mail cegs@fujikur rubber.com

Head Office :

2-11-20 Nishi-gotanda, Shinagawa-ku, TOKYO
141-0031, JAPAN
Phone: 81-3-3490-2111
Facsimile: 81-3-3490-2170